

P400 ATEX

Diaphragm pumps

- **Fluid connections:** 1" 1/2 BSP - DN 40
- **Air connection:** 1/2" BSP
- **Max flow-rate:** 380 lt/min
- **Max air pressure:** 8 bar
- **Max delivery head:** 80 m
- **Max Suction Lift Dry:** 5 m
- **Max Suction Lift Wet:** 9,8 m
- **Max Solid passing:** 8 mm
- **Noise level:** 78 dB
- **Max Viscosity:** 40.000 cps
- **Displacement per stroke:** 1200 CC~

Available versions



PP+CF



PVDF+CF



ALU



SS

PERFORMANCE

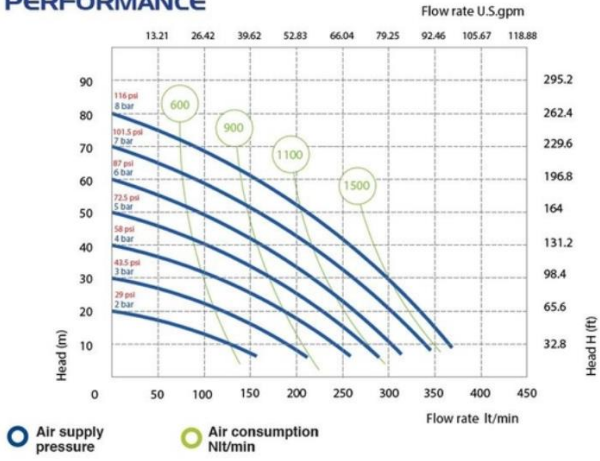

The curves and performance values refer to pumps with submerged suction and a free delivery outlet with water at 20°C, and vary according to the construction material.

DIMENSIONS

	A	B	C	WIGHT	TEMPERATURE	
PP	454 mm	260 mm	564 mm	20 Kg	- 4 °C	+ 65 °C
PVDF	454 mm	260 mm	564 mm	20 Kg	- 20 °C	+ 95 °C
ALU	445 mm	260 mm	563 mm	24 Kg	- 20 °C	+ 95 °C
SS	361 mm	260 mm	502 mm	27 Kg	- 20 °C	+ 95 °C

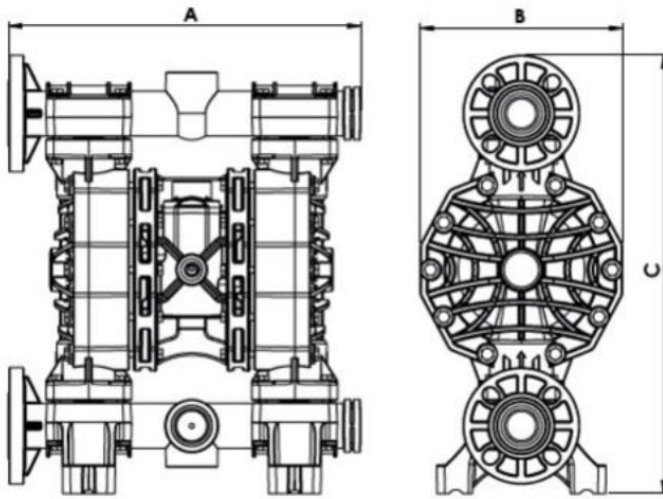

Contact us for more info: info@advantage-eu.com