

# P120 ATEX

## Diaphragm pumps

- **Fluid connections:** 1" BSP
- **Air connection:** 3/8" BSP
- **Max flow-rate:** 120 lt/min
- **Max air pressure:** 8 bar
- **Max delivery head:** 80 m
- **Max Suction Lift Dry:** 5 m
- **Max Suction Lift Wet:** 9,8 m
- **Max Solid passing:** 4 mm
- **Noise level:** 72 dB
- **Max Viscosity:** 25.000 cps
- **Displacement per stroke:** 200 CC~

## Available versions



PP+CF



PVDF+CF



ALU



SS

## PERFORMANCE

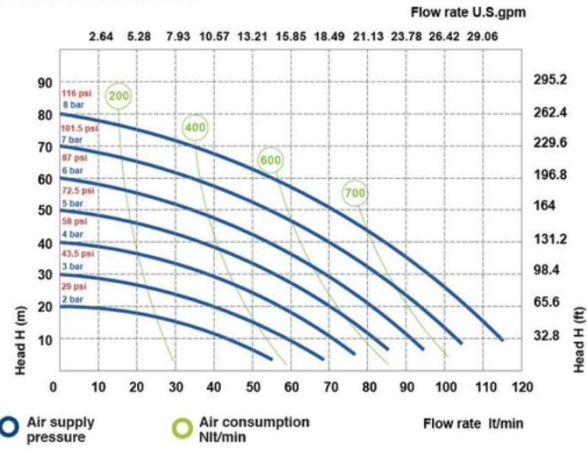

The curves and performance values refer to pumps with submerged suction and a free delivery outlet with water at 20°C, and vary according to the construction material.

## DIMENSIONS

	A	B	C	WIGHT	TEMPERATURE	
PP	293 mm	178 mm	280 mm	5 Kg	-4 °C	+ 65 °C
PVDF	293 mm	178 mm	280 mm	6 Kg	-20 °C	+ 95 °C
SS	258 mm	177 mm	295 mm	10 Kg	-20 °C	+ 95 °C

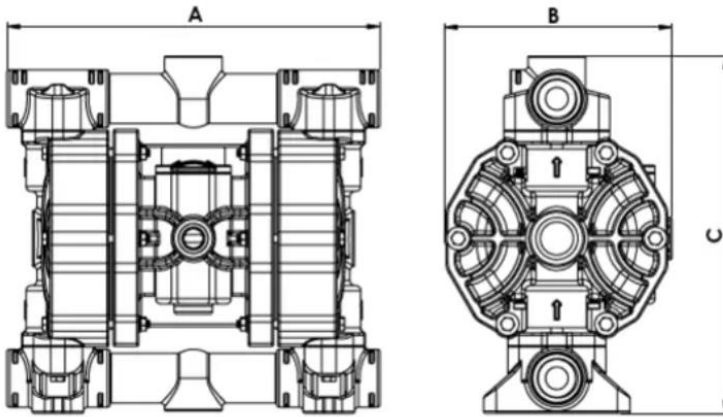

Contact us for more info: [info@advantage-eu.com](mailto:info@advantage-eu.com)